



Octal Valve Controller System on Chip

MC34SB0800

新規採用非推奨

このページでは、新規設計を推奨しない製品に関する情報を掲載しています。

Last Updated: Sep 26, 2023

The NXP® MC34SB0800 Octal Valve and Pump Controller System on Chip consists of four low-side drivers regulated and four low-side drivers digitals, plus a high side to control a DC motor.

- Suitable for loads with high inrush current and allows driving to high frequency (up to 5 kHz)
- With SPI communication, you can perform control and diagnostic functions directly on the chip
- Designed for harsh environments and includes self-recovery features due to the embedded supervision that allows extensive safety monitoring
- A predriver MOSFET increases safety by turning off all valves in the event of any issue
- Ideal solution to drive hydraulic or pneumatic valves without "smart electronics"
- Processor Expert® component Valve Driver and Embedded Software Valve Driver enables rapid embedded application development.

MC34SB0800 Octal Valve and Pump Controller Block Diagram Block Diagram

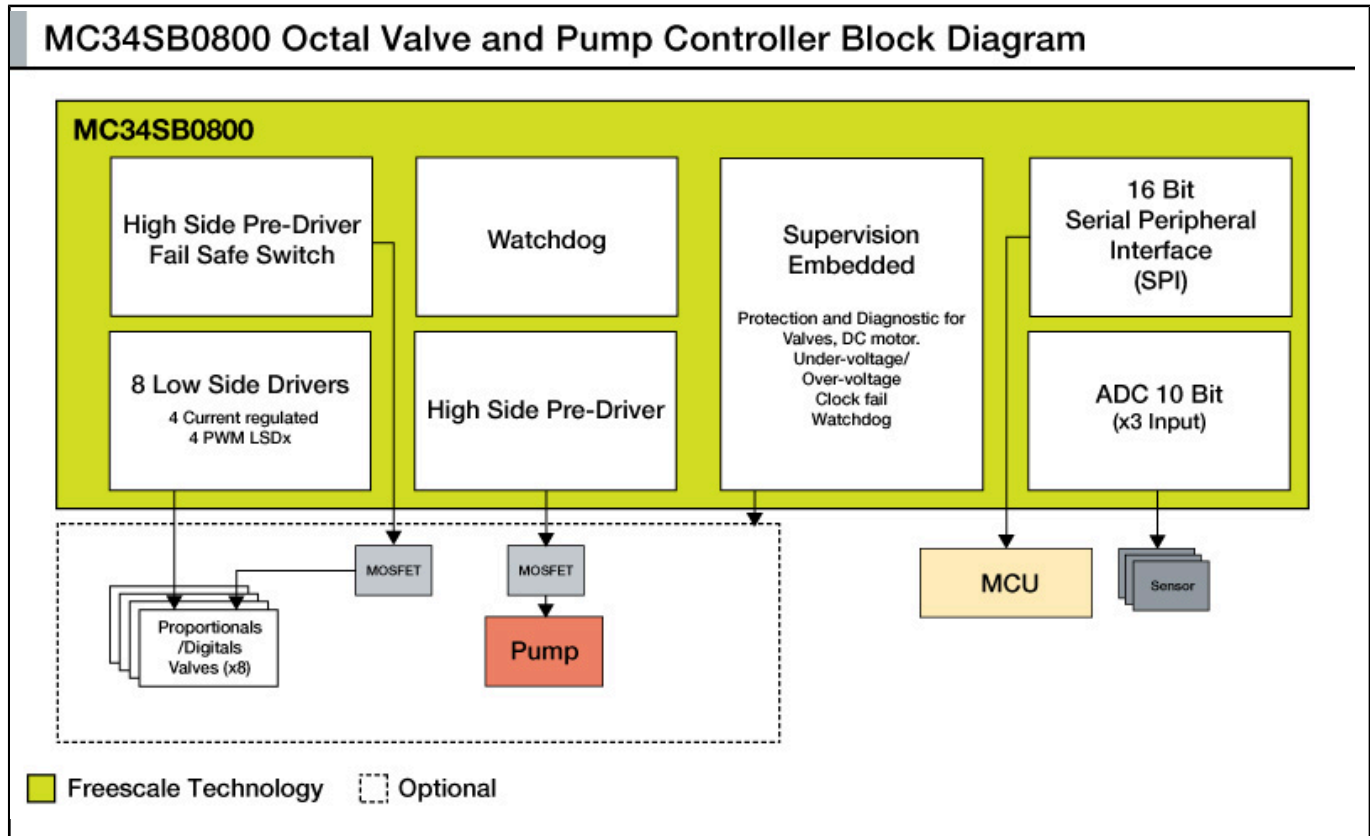

View additional information for [Octal Valve Controller System on Chip](#).

Note: The information on this document is subject to change without notice.

www.nxp.com

NXP and the NXP logo are trademarks of NXP B.V. All other product or service names are the property of their respective owners. The related technology may be protected by any or all of patents, copyrights, designs and trade secrets. All rights reserved. © 2024 NXP B.V.