



System Basis Chip with CAN High-Speed and LIN Interface

MC34903

新規採用非推奨

このページでは、新規設計を推奨しない製品に関する情報を掲載しています。

Last Updated: Jan 19, 2024

The NXP® MC34903 is an analog companion chip for the MCU and combines several voltage regulators, interface, monitoring and control, and other features to enhance present module designs targeting the industrial market.

- Built-in enhanced high-speed CAN interface (ISO11898-2 and -5) with local and bus failure diagnostics, protection, and fail-safe operation modes
- The SBC may include zero or one LIN 2.1 interface with LIN output pin switches
- It includes up to three wake-up input pins that can also be configured as output drivers for flexibility
- This device is powered by SMARTMOS® technology

Simplified Application Drawing Block Diagram

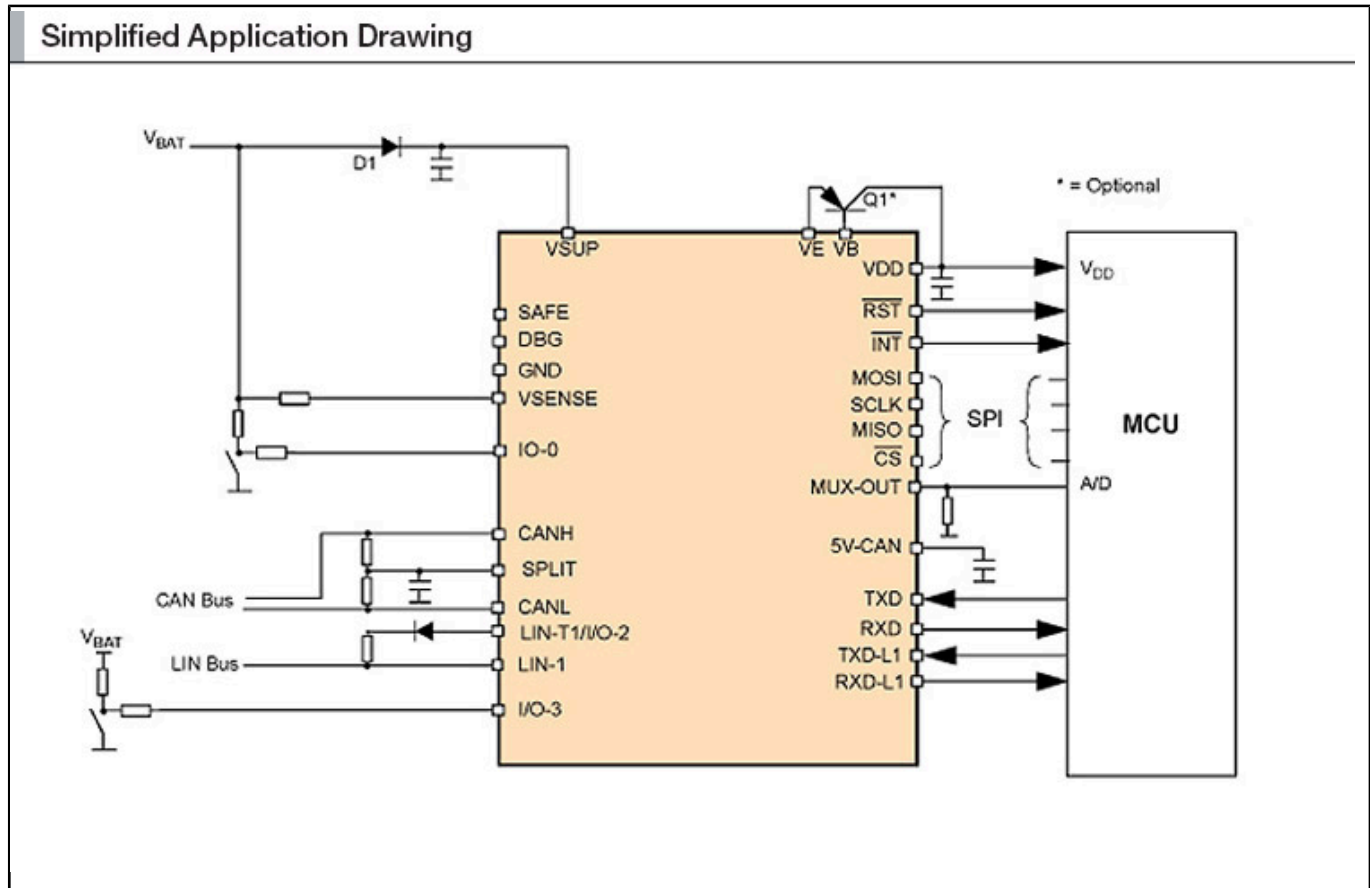

View additional information for [System Basis Chip with CAN High-Speed and LIN Interface](#).

Note: The information on this document is subject to change without notice.

www.nxp.com

NXP and the NXP logo are trademarks of NXP B.V. All other product or service names are the property of their respective owners. The related technology may be protected by any or all of patents, copyrights, designs and trade secrets. All rights reserved. © 2024 NXP B.V.