



MicroUSB Interface IC

MC34825

アーカイブス

このページには、製造中止（生産終了）となった製品の情報が記載されています。本ページに記載されている仕様および情報は、過去の参考情報です。

Last Updated: Apr 8, 2022

Archived content is no longer updated and is made available for historical reference only.

The 34825 is designed to support the Universal Charging Solution (UCS) recommended by the OMTP (Open Mobile Terminal Platform), as well as to use the same 5-pin micro or mini-USB connector for other wired accessories. The 34825 supports various types of external power supplies, such as a dedicated ac/dc adapter or a USB port, to charge the battery. It has functions built in to identify the type of the power supply, and sets low or high charging current, based on the current capability of the power supply. The 34825 monitors the power supply, and offers an up to 28 V of over-voltage protection (OVP) to the cellphone against failed power supplies. The 34825 also contains analog switches to multiplex the 5 pins, to support UART and high speed USB data communication, mono or stereo audio headset with or without a microphone and a cord remote controller, manufacturing or research-and-development (R/D) test cables, and other accessories.

Freescale MC34825 Power Actuation Block Diagram Block Diagram

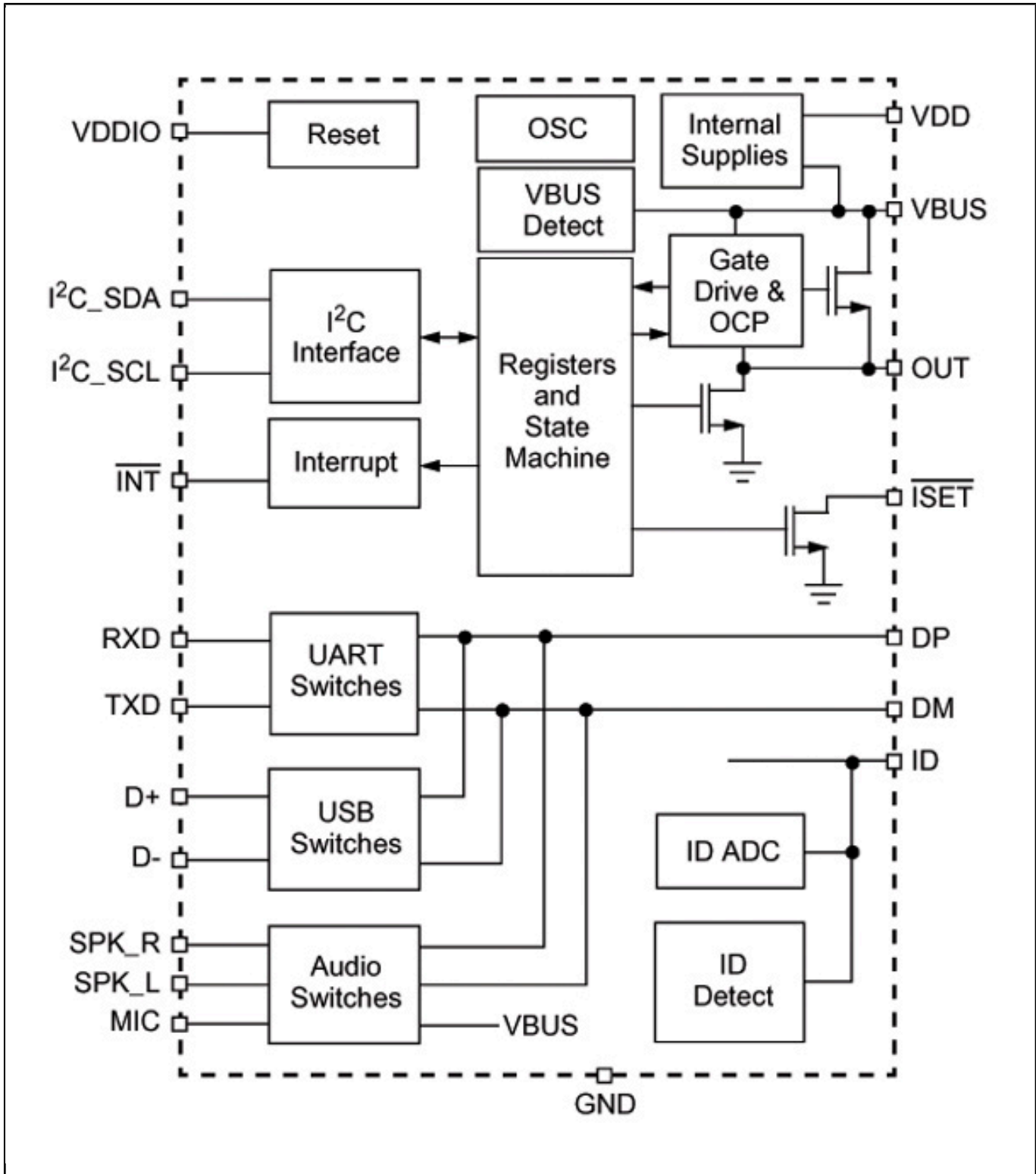

View additional information for [MicroUSB Interface IC](#).

Note: The information on this document is subject to change without notice.

www.nxp.com

NXP and the NXP logo are trademarks of NXP B.V. All other product or service names are the property of their respective owners. The related technology may be protected by any or all of patents, copyrights, designs and trade secrets. All rights reserved. © 2024 NXP B.V.