



# Two Cylinder Small Engine Control IC

## MC33814

Last Updated: Jul 20, 2023

The NXP® 33814 is an engine control analog power IC delivering a cost-optimized solution for managing one and two-cylinder engines.

- With six drivers, three pre-drivers, a 5.0 V regulator for the MCU, a protected external sensor supply, and a high level of integration, the IC offers an ideal response to contemporary market requirements.
- The innovative VRS system optimizes noise immunity under cranking conditions.
- Diagnostic and protection features present on all outputs allow applications to operate with greater safety.
- The device is packaged in a 48 pin LQFP with an exposed pad for a minimum space footprint.

## Two Cylinder Small Engine Control IC Block Diagram

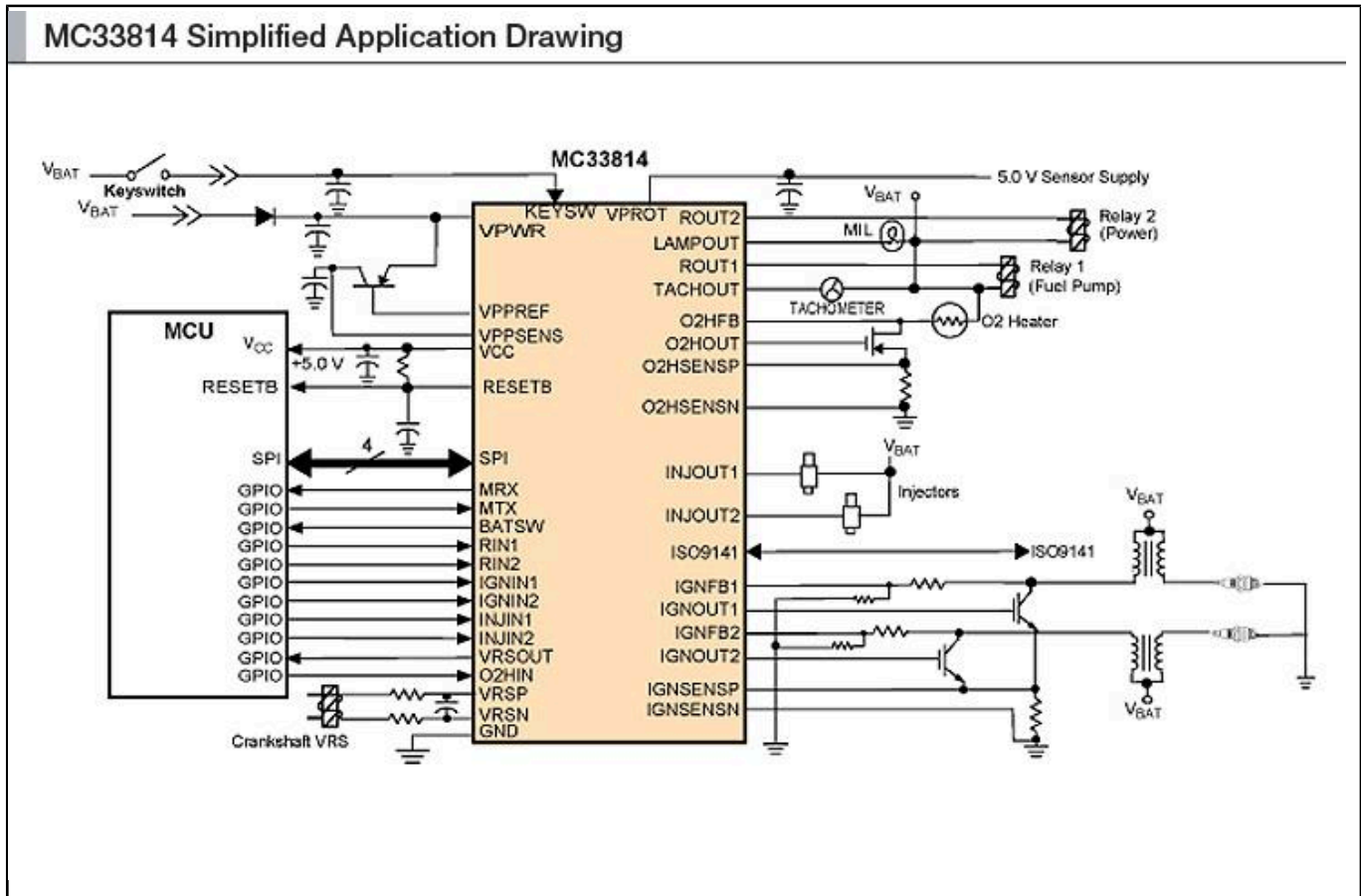

View additional information for [Two Cylinder Small Engine Control IC](#).

Note: The information on this document is subject to change without notice.

[www.nxp.com](http://www.nxp.com)

NXP and the NXP logo are trademarks of NXP B.V. All other product or service names are the property of their respective owners. The related technology may be protected by any or all of patents, copyrights, designs and trade secrets. All rights reserved. © 2024 NXP B.V.