



Power Supply with Multiple Linear Regulators

MC33730

新規採用非推奨

このページでは、新規設計を推奨しない製品に関する情報を掲載しています。

Last Updated: Mar 18, 2024

The NXP® MC33730 is a multiple output power supply integrated circuit that incorporates a switching regulator with an adjustable frequency oscillator for automotive applications.

- The integrated circuit incorporates a switching regulator which operates over a wide input voltage range from +4.5 V to +26.5 V
- The step-down switching regulator uses a fixed frequency PWM voltage mode control
- It has a 3.5 A current limit (typical) and the slew-rate is adjustable via a control pin to reduce switching noise
- The switching regulator has an adjustable frequency oscillator, which allows the user to optimize its operation over a wide range of input voltages and component values

Power Supply with Multiple Linear Regulators Block Diagram

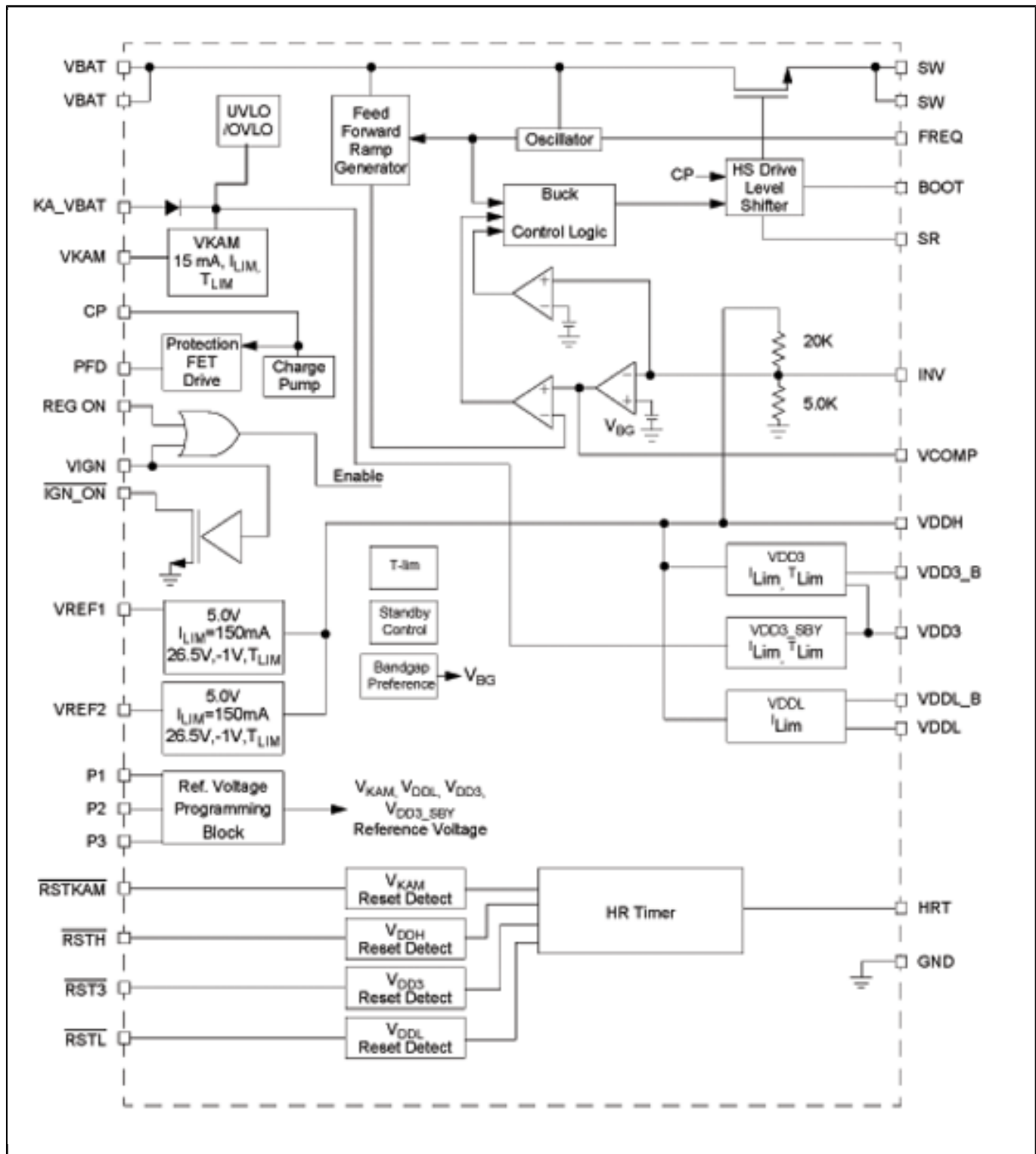

View additional information for [Power Supply with Multiple Linear Regulators](#).

Note: The information on this document is subject to change without notice.

www.nxp.com

NXP and the NXP logo are trademarks of NXP B.V. All other product or service names are the property of their respective owners. The related technology may be protected by any or all of patents, copyrights, designs and trade secrets. All rights reserved. © 2024 NXP B.V.