



VR5500 / FS5502 PMIC Evaluation Board

KITVR5500AEEVM

Last Updated: Apr 19, 2024

The KITVR5500AEEVM provides flexibility to play with all the features of the device and make measurements on the main part of the application. The KL25Z MCU installed on the board combined with the FlexGUI software allows access to the registers in read and write mode. All regulators are accessible through connectors. Nonuser signal, like DC/ DC switcher node is mapped on test points.

This board can be operated in Emulation or OTP mode. In Emulation mode, as long as the power is supplied, the board configuration stays valid. The OTP mode uses the fused configuration.

VR5500, High Voltage PMIC Block Diagram Block Diagram

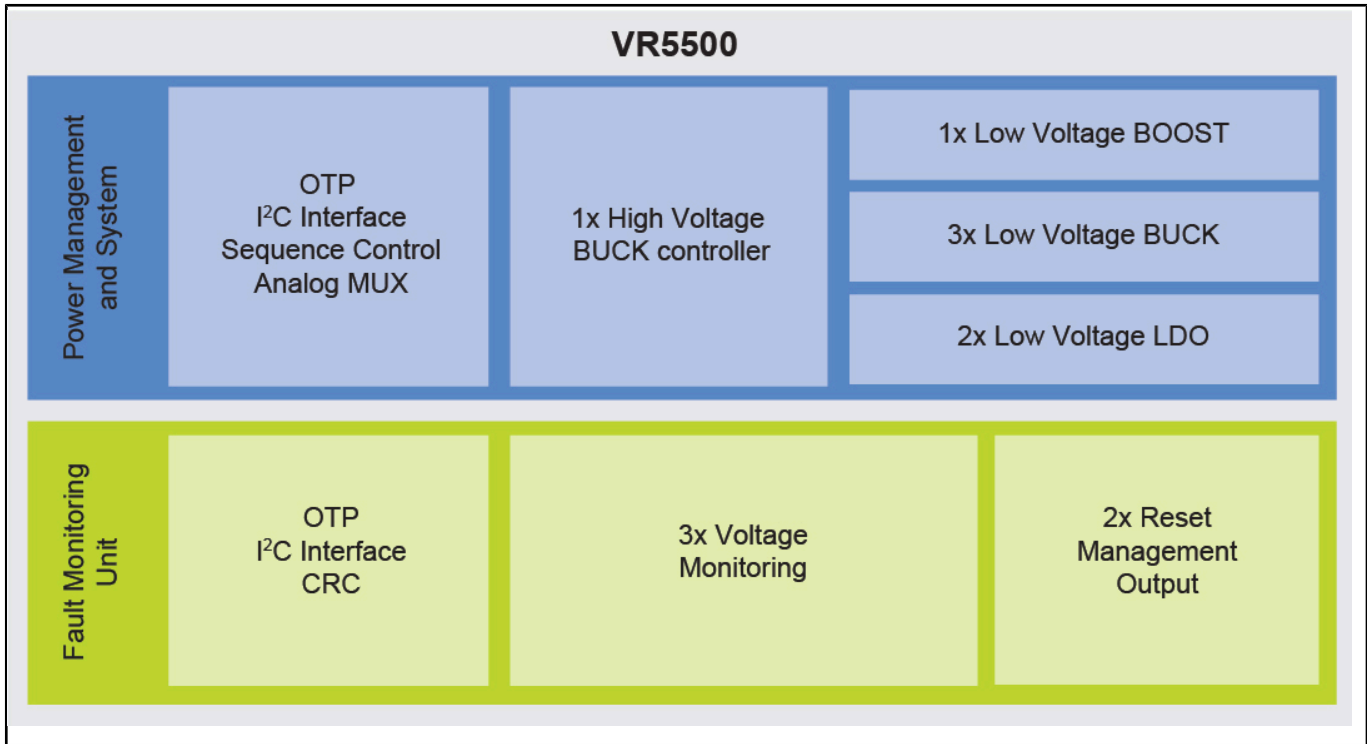

FS5502, High Voltage PMIC Block Diagram Block Diagram

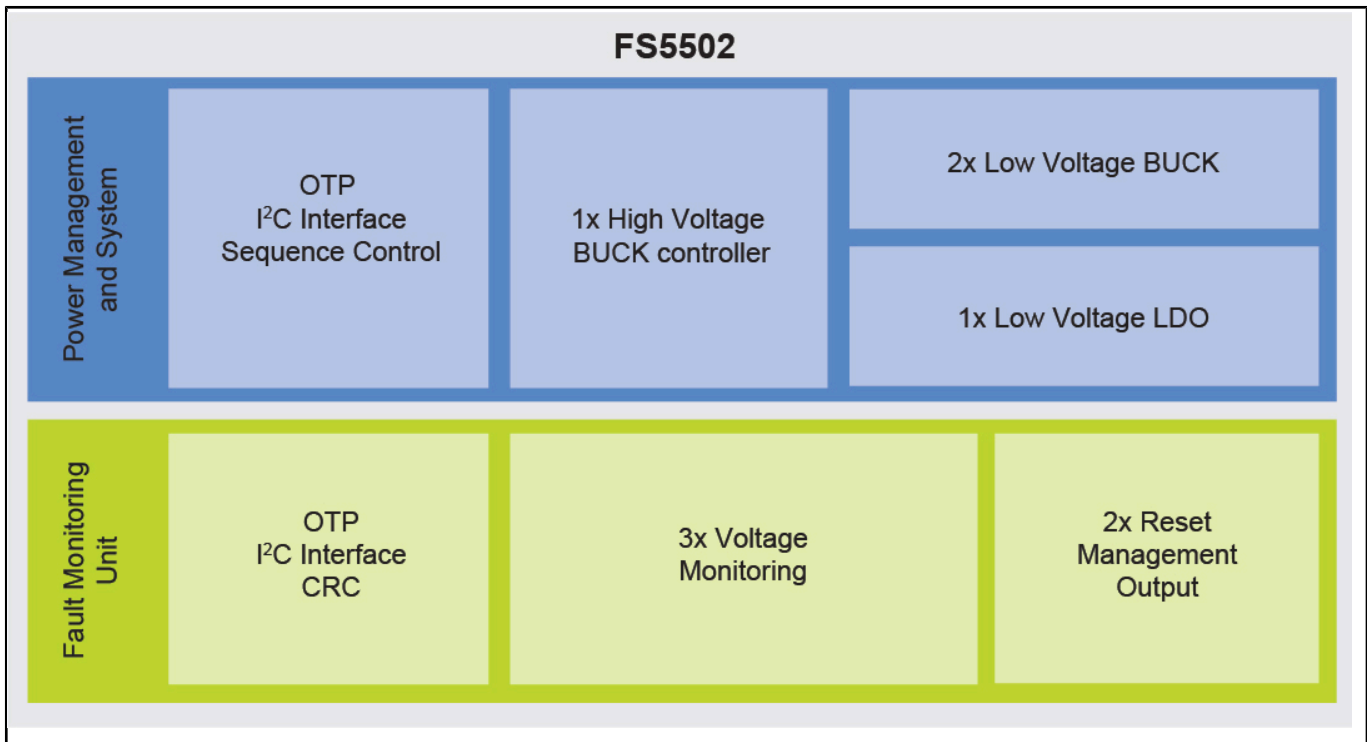

Note: The information on this document is subject to change without notice.

www.nxp.com

NXP and the NXP logo are trademarks of NXP B.V. All other product or service names are the property of their respective owners. The related technology may be protected by any or all of patents, copyrights, designs and trade secrets. All rights reserved. © 2024 NXP B.V.