



QorIQ® Qonverge BSC9131 RDB for Femtocell Base Station Development

BSC9131RDB

Last Updated: Nov 29, 2022

The QorIQ® Qonverge BSC9131 reference design board (RDB) application development system enables development of L1, L2 and L3 protocol stacks and applications ported above L3 for wireless base station applications. The reference design board can also be used to evaluate general embedded and industrial applications. The BSC9131 RDB allows for verification of BSC9131 processor device operation and provides a high level of end-to-end system performance characterization.

The highly integrated BSC9131 targets the evolving small cell base station market and combines the e500 Power Architecture CPU and SC3850 StarCore® DSP with MAPLE-B2F baseband acceleration processing elements. Together, they address the need for a high-performance, cost-effective, integrated solution that handles all required processing layers without the need for additional external processing devices.

BSC9131RDB BD IMG Block Diagram

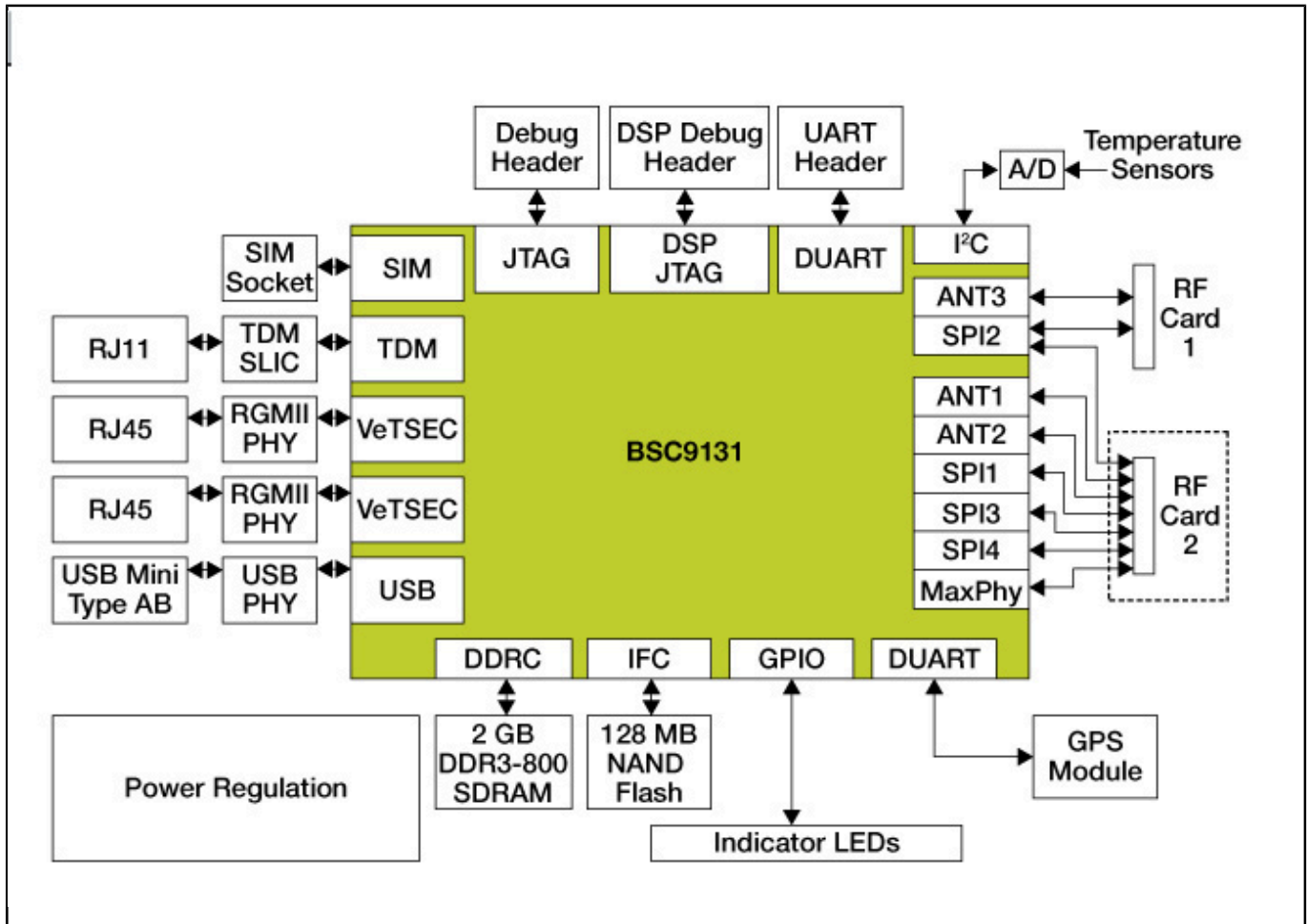

View additional information for [QorIQ® Qonverge BSC9131 RDB for Femtocell Base Station Development](#).

Note: The information on this document is subject to change without notice.

www.nxp.com

NXP and the NXP logo are trademarks of NXP B.V. All other product or service names are the property of their respective owners. The related technology may be protected by any or all of patents, copyrights, designs and trade secrets. All rights reserved. © 2024 NXP B.V.